

Residential Electric Policy

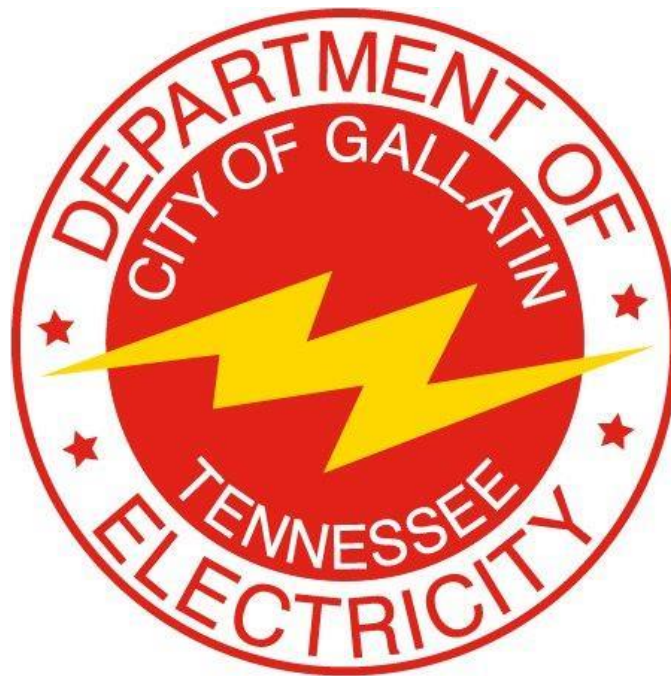

7/19/16

Table of Contents

General Information.....	3
Construction.....	3
Ownership	3
Underground Service.....	3
Apartments/Multi-Unit Dwellings.....	3
Modular and Manufactured Homes.....	3
Secondary Termination Enclosures.....	4
Meter Bases.....	5
Temporary Boards.....	5
Guidelines.....	5
Diagram.....	6
Specifications.....	7
Underground Service.....	7
Pole, Customer Owned.....	7
Underground Primary/Secondary.....	8
Diagrams for Contractors.....	9
Fiberglass Transformer Pad.....	9
Pad mount Transformer Spacing.....	10
Conduit Layout (Overhead Primary).....	11
Conduit Layout (Underground Primary).....	12
Meter Base Label.....	13

All meter bases shall be Gallatin Dept. of Electric (GDE) approved meter bases, see GDE meter base policy. All meter base locations must be approved by GDE's Engineering Dept.

Construction

GDE's normal primary construction is overhead (OH). Customers that require more than a 250' span of primary to serve a residential dwelling will pay for the estimated cost of construction before GDE will begin construction. The customer will sign a "Residential Aid to Construction Contract" with GDE. GDE requires a 30' cleared right of way for line construction. If a customer wishes to have underground (UG) primary construction, the customer will pay the cost difference of OH vs UG before construction will begin, and also install conduit and sleeves per GDE conduit layout.

Ownership/Repairs

Meter bases, service conduit from meter base to GDE's secondary equipment, risers, and point of attachment are the customer's property and the customer's responsibility to supply, maintain, and repair. GDE owns and maintains OH and UG service wire, except on underground services 600 amps and above, and OH service connections. The customer installs, owns, and maintains the conduit and service wire on underground services 600 amps and above. The service size is the sum of all meter bases per building. Residential customers changing out meter bases, doing panel upgrades, or any major electrical repair will be required to update service to GDE specs as well as meeting all current NEC/NESC code requirements. Any overhead service installation must be approved by GDE Engineering Dept.

Underground Service

Underground electric service is required for all new residential housing in new developments. New residential housing in existing overhead developments must have underground service unless overhead is preapproved by GDE Engineering Dept. The customer is responsible for all ditch and conduit installations (see GDE Underground Service Specs, pg8). Customers with direct buried services that require repairs will be responsible for all ditch and conduit installations (see GDE Underground Service Specs, pg8). All conduit shall be inspected by GDE or GDE's approved agent before being covered.

Apartments/Multi-Unit Dwellings

The customer installs, owns, and maintains the conduit and service wire on underground services 600 amps and above. The service size is the sum of all meter bases per building. Multi-tenant developments will be required to provide, install, and maintain service conduit and wire to all buildings if one building exceeds the 600amp service size. GDE will not mix GDE service wire and customer service wire in these developments. All apartment/multi-unit dwellings shall have meter bases numbered to GDE specs (see Meter Base Label, pg14). Multi-gang meter bases must be approved by GDE's Metering Dept. Meter troughs will not be allowed (see Secondary Termination Enclosures, pg4).

Modular and Manufactured Homes

Modular homes are defined as a house that comes in more than one piece and assembled on the home site. Manufactured homes are one piece houses with axles, commonly referred to as "mobile homes" or "trailers". Meter bases may only be mounted on modular homes that have a permanent foundation, tongue removed, and are certified by the manufacturer that the building is rated for such an installation. These services will be underground (see GDE Underground Service Specs, pg8). Homes not meeting these requirements and all manufactured homes will have underground service to a meter pedestal (must

be approved by GDE Metering Dept.) no more than 20' from building (see GDE Underground Service Specs, pg8). Overhead service to risers or service poles will only be allowed if preapproved by the GDE Engineering Dept. The service poles will meet the minimum specs listed in GDE Pole Setting Specs along with all current NEC/NESC code requirements.

Secondary Termination Enclosures

GDE shall not connect to any new troughs. Secondary termination enclosures (provided by the Customer) will be used on all new services requiring multiple meters where ganged meter bases are not used. Existing troughs shall be replaced with secondary termination enclosures under the following circumstances: Adding new load, upgrading service, adding a new service, or replacing GDE line side conductors.

Each individual service in the termination cabinet shall be labeled by unit number, suite number, or space number on the service cable for disconnect/reconnect purposes. The labeling must be approved by the GDE Engineering Dept. All conductors shall be routed behind the termination cabinet buss work.

Secondary termination enclosures can be purchased at local electrical distributors. Enclosures are the property of the Customer. GDE requires a GDE lock on these enclosures. A GDE employee will unlock the enclosure for the Customer when necessary.

The following are acceptable part numbers for termination enclosures. Any enclosure not listed must approved by GDE's Engineering Dept.

CMC (Connector Manufacturing Company) Wall Mounted three phase

Catalog Number	Cond. Range AWG	No. of Cond. Per Phase	W	D	H	Phase Cover	U.L. Listed Amp Rating	
			Dimensions - Inches				Copper	Aluminum
LWTE21-500	10-500 kcmil	21	32.00	16.00	51.00	TEC-30	3800	3100
LWTE14-750	2-750 kcmil	14	32.00	16.00	51.00	TEC-30	3325	2695
LWTE14-1000	1/0-1000 kcmil	14	32.00	16.00	51.00	TEC-30	3815	3115

A disconnect is allowed in front of the termination enclosure. A disconnect is not allowed between the termination enclosure and the meter base.

Meter Bases

- Location shall be approved by GDE's Engineering Dept.
- Shall be surface mounted and on a permanent structure controlled by the Customer.
- Shall not be located in areas that are closed off by porches, decks, patios, fences, walls, screens, etc.
- GDE shall have unobstructed access to meter base.
- Shall have a 6' clearance from any obstruction in front of meter base
- Shall be mounted 5'6" from ground to center of meter base.
- GDE/Customer service wire will enter left side of meter base, customer load wires will exit right side facing meter base.
- Shall be an approved meter base.
- Shall be installed to NEC requirements.

Temporary Electric Service Policy

The Gallatin Department of Electricity (GDE) will provide electricity to customer owned temporary boards according to the following guidelines.

1. Temporary boards must be labeled with the address and lot number, and pass an electrical inspection by the State Electrical Inspector each time the board is installed or relocated.
2. Temporary boards must be underground fed temporary board unless approved by the GDE Engineering Department.
3. Temporary board location must be approved by the GDE Engineering Department.
4. Temporary boards that are approved for overhead installation shall be rigidly installed in the ground (2' min for post and braces) with braces or guys to adequately support the overhead service conductors and the weight of a 250lb man on a ladder leaned against the temporary board. There shall be an eyebolt attachment for GDE's service conductors. The attachment point and ground clearance to service wire shall meet the National Electric Code and National Electric Safety Code. The overhead temporary board shall not be installed more than 100' from GDE's approved pole.
5. Temporary boards requiring more than 100' of overhead service wire or when temporary construction is required, the total installation and removal cost will be paid by customer before work will begin. The cost to install a transformer to feed a temporary board will be \$200.00.
6. Customers or contractors will not remove a temporary board until the meter and service wires have been disconnected and/or removed.
7. GDE will charge a \$100.00 temporary board fee. This amount covers the installation and removal of the service wire. If additional trips are made, there will be extra charges. This charge does not include meter service charge and deposit.

GENERAL CONSTRUCTION NOTES:

- 1) The GDE engineer will spot the temporary board location upon request.
- 2) The temporary board shall be installed at least 3' from and no more than 18' from GDE's approved service point.
- 3) Temporary electric service boards are not to be installed on GDE poles or trees.
- 4) Each temporary board must be labeled with address and lot number, and pass an electric inspection by the State Electrical Inspector each time the board is installed or relocated.
- 5) The temporary board clearance from other objects must meet all NEC and NESC requirements.

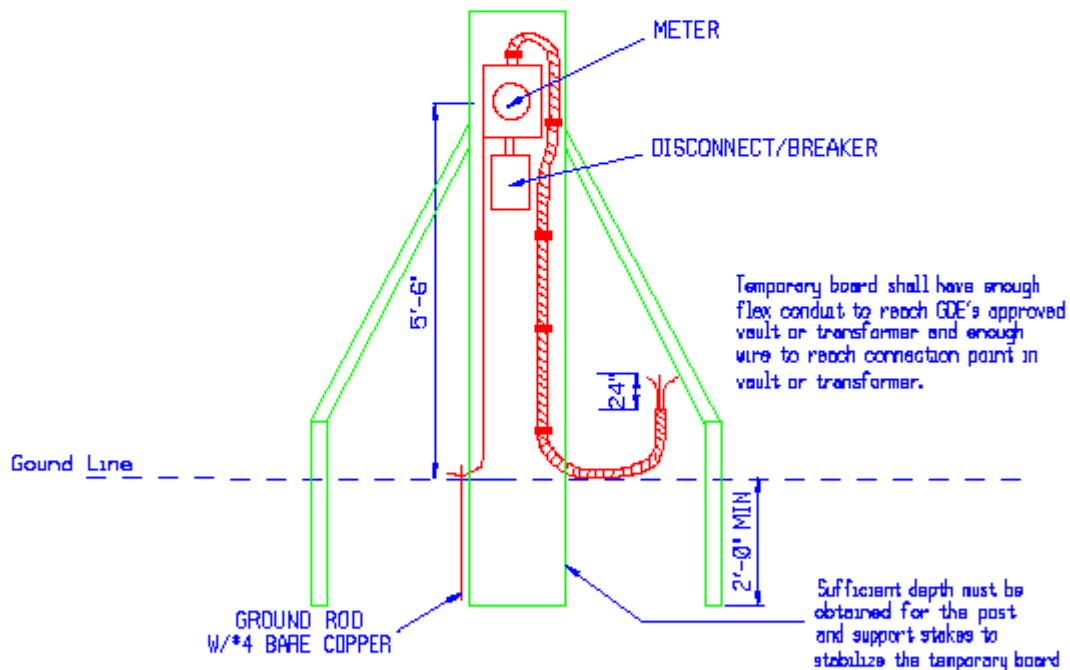

IMPORTANT NOTE:

CUSTOMERS OR CONTRACTORS WILL NOT REMOVE A BOARD UNTIL THE METER AND THE SERVICE WIRES HAVE BEEN REMOVED.

<p>G D E</p>	<p>UNDERGROUND TEMPORARY BOARD SERVICE</p>	<p>DATE 2/14/14</p>
		<p>STANDARD NUMBER UG TB</p>

GDE Underground Service Specs.

Inspection	Inspection
Trench	<ul style="list-style-type: none"> *Shall meet all OSHA standards *Shall be free of construction debris and large/sharp rocks *Shall be a straight line from GDE secondary box to meter base *Shall not be located under any permanent structures *Backfill, soil free of material that may damage conduit or gravel.
Conduit	<ul style="list-style-type: none"> *Conduit will be inspected prior to backfilling ditch. *Service size 200-400 amp 3" schedule 40 PVC conduit Service size of 600 amp shall be 2-3" schedule 40 PVC conduits *Expansion joint required on all services below meter base *Conduit above ground shall be schedule 80 PVC *Only two 90° 24" radius PVC Schedule 80 elbows may be used. *30" minimum depth with a minimum 12" separation (vertical and horizontal) from other utilities (excluding AT&T/Comcast service drops). *Pull String required
Meter Base	*Must be installed and meet GDE meter base policy
Ground rod/wire	*Must be installed per NEC code requirements. (Driven in undisturbed soil)

*** All inspection requirements must be met before notifying GDE for an inspection.**

GDE Pole Setting Specs.

Pole Height	Set depth with dirt backfill
25'	5'
30'	5'
35'	5.5'

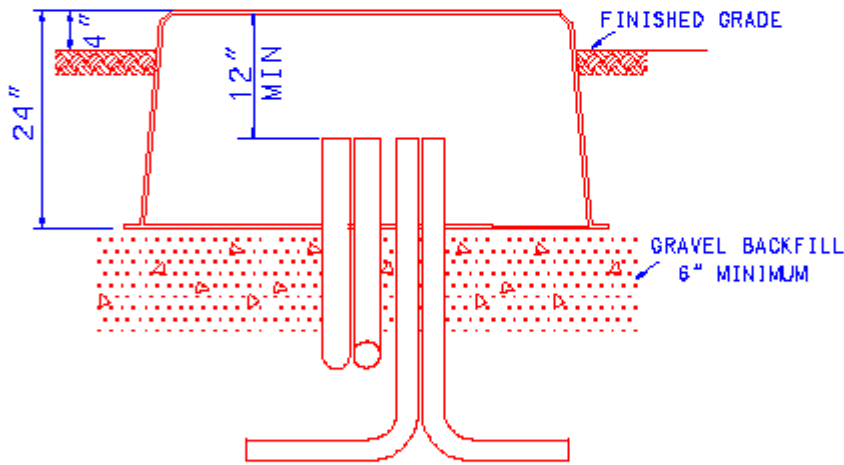
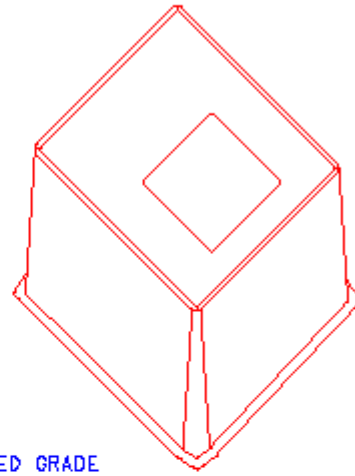
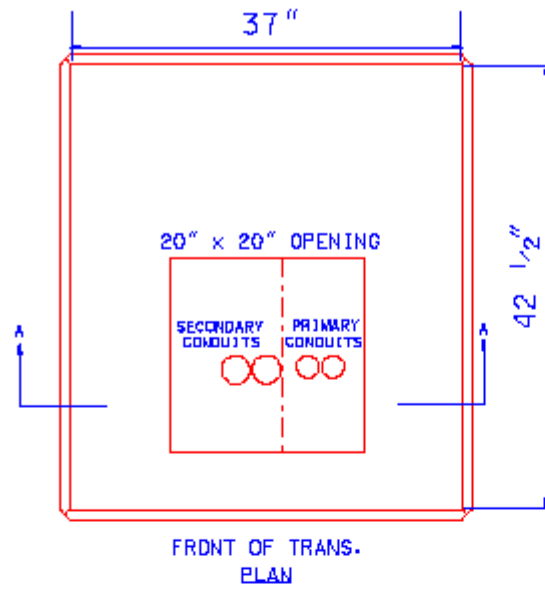

NOTE:

SECTION A-A

- 1 - PRIMARY & SECONDARY CONDUITS TO BE LOCATED AS SHOWN ABOVE.
- 2 - CONDUITS TO STOP AT LEAST 12" BELOW TOP OF PAD.
- 3 - PRIMARY CONDUITS TO BE 48" DEEP.
- 4 - SECONDARY CONDUITS TO BE 30" DEEP.
- 5 - PAD TO SET ON GRAVEL BACKFILL FROM BOTTOM OF DITCH TO PAD BOTTOM.
- 6 - CONDUIT DAMAGED BEFORE WIRE IS INSTALLED MUST BE REPLACED/REPAIRED BY DEVELOPER.

GDE

FIBERGLASS PAD DETAIL
SINGLE PHASE PAD MOUNTED
TRANSFORMER

DATE 2/15/13

STANDARD
NUMBER

UMF-1P

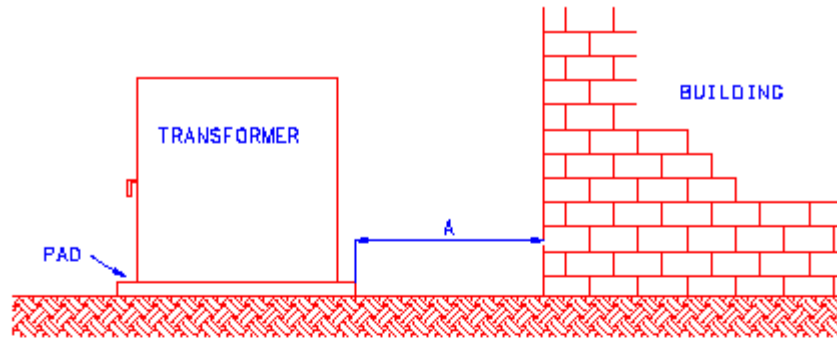

<u>DIMENSION A</u>	<u>TRANSFORMER KVA</u>	<u>BUILDING WALL & EAVES</u>
10'	0-75	NOT FIRE RESISTANT
20'	76-333	NOT FIRE RESISTANT
30'	334 AND LARGER	NOT FIRE RESISTANT
3'	ALL SIZES	FIRE RESISTANT (8" BRICK, ETC.)

ELEVATION VIEW

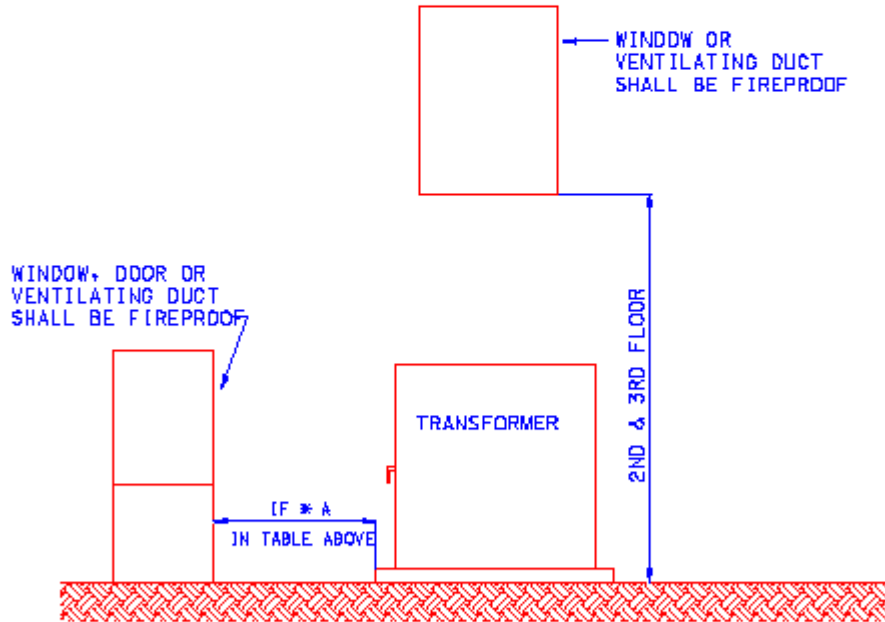

ELEVATION VIEW

GDE	TYPICAL SITING REQUIREMENTS FOR PAD-MOUNT TRANSFORMER	DATE: 11/30/00
		STANDARD NUMBER UMT-1

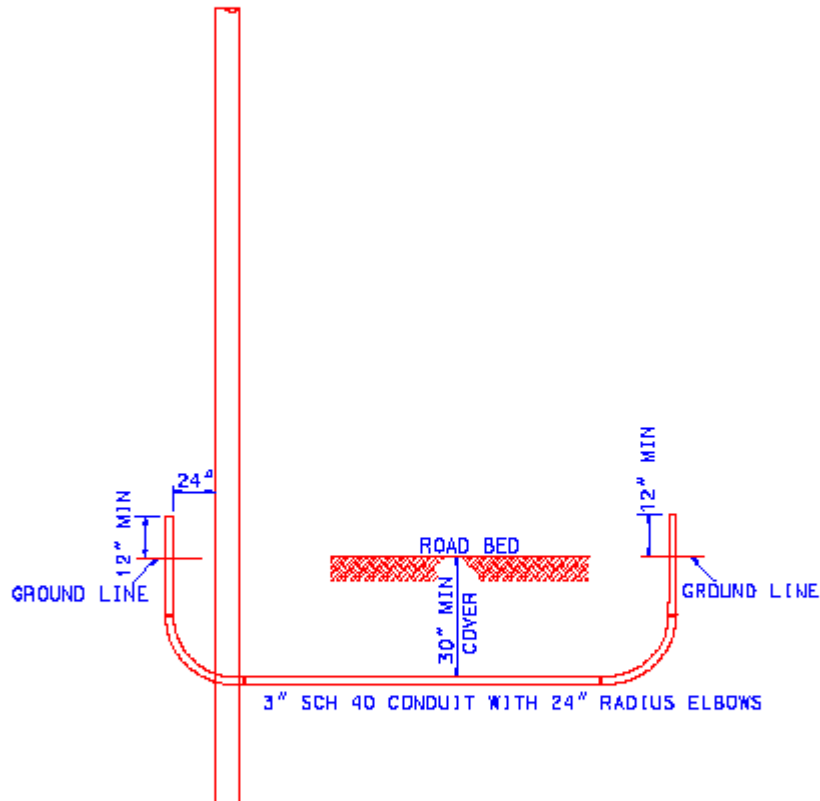
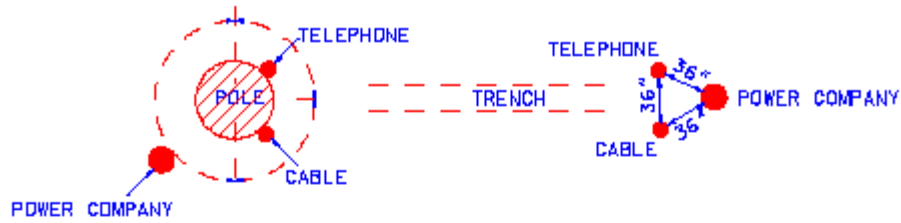

NOTES:

- 1) CONTRACTOR TO SUPPLY AND INSTALL CONDUIT WITH PULL STRING
- 2) CONTRACTOR TO SUPPLY AND INSTALL CAPS AT BOTH ENDS OF CONDUIT
- 3) PULL STRING TO HAVE AT LEAST 500 LB TENSILE STRENGTH
- 4) CABLE TV AND PHONE CONDUITS INSTALLED ON STREET SIDE OF POLE
- 5) POWER COMPANY CONDUIT TO BE INSTALLED ON SIDE OF POLE AWAY FROM STREET
- 6) CONDUIT DAMAGED BEFORE WIRE IS INSTALLED MUST BE REPLACED/REPAIRED BY DEVELOPER

<h1>GDE</h1>	UNDERGROUND SECONDARY CONDUIT SYSTEM	DATE: 4/1/04
		STANDARD NUMBER USEC

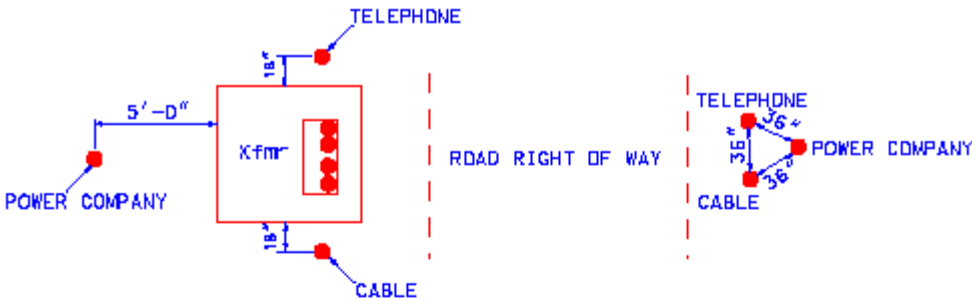

NOT TO SCALE

NOTES:

POWER COMPANY CONDUITS AND TRANSFORMER TO BE LOCATED IN THE UTILITY EASEMENT

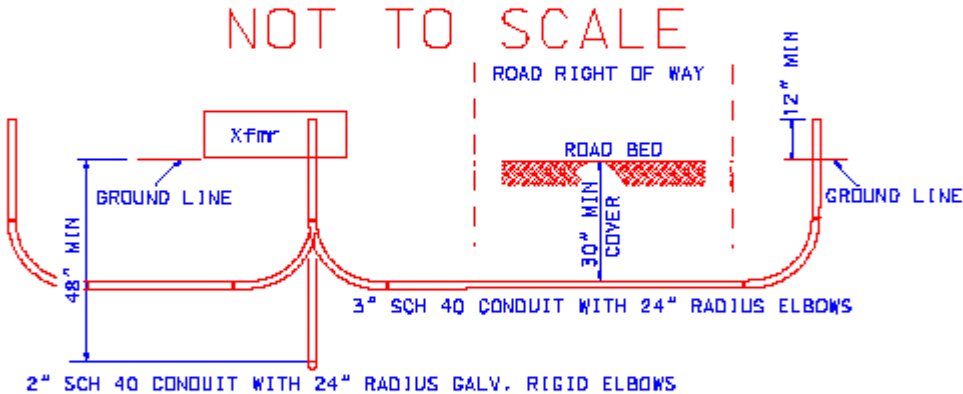

NOT TO SCALE

NOTES:

- 1) CONTRACTOR TO SUPPLY AND INSTALL CONDUIT WITH PULL STRING
- 2) CONTRACTOR TO SUPPLY AND INSTALL CAPS AT BOTH ENDS OF CONDUIT
- 3) PULL STRING TO HAVE AT LEAST 500 LB TENSILE STRENGTH
- 4) ALL CONDUIT TO BE INSPECTED BY GDE PRIOR TO BACKFILLING
- 5) CONDUIT DAMAGED BEFORE WIRE IS INSTALLED MUST BE REPLACED/REPAIRED BY DEVELOPER

GDE	UNDERGROUND DISTRIBUTION SYSTEM	DATE: 7/14/05
		STANDARD NUMBER UDIST

Wiring troughs are no longer allowed, must now use secondary tap boxes.

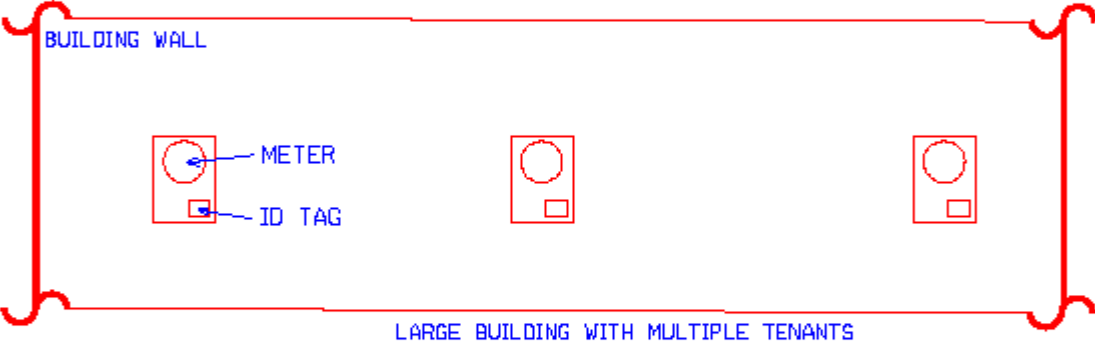
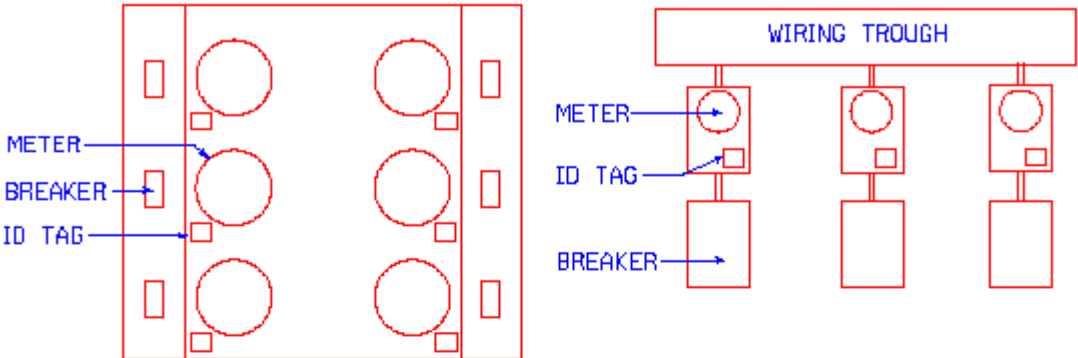

NOTES:

- 1- Buildings such as apartment buildings, retail strip centers, duplexes, triplexes, town homes, and etc. which have more than one meter shall have all meters labeled to identify the premises they serve.
- 2- The label shall have the apartment/building number or street address.
- 3- The label shall be outdoor rated brass or stainless steel.
- 4- The labels shall be attached to the meter base with rivets or screws.
- 5- The identification numbers/letters shall be stamped or engraved.
- 6- The identification numbers/letters shall have a character size of at least 1/8" in height.

<h1>GDE</h1>	LABELING FOR MULTI-METERED INSTALLATIONS	DATE 7/28/15
		STANDARD NUMBER LAB-1