

Commercial Electric Policy



7/19/16

Table of Contents

General Information.....	3
Construction	3
Ownership.....	4
Multi-Unit/Multi-Service Buildings.....	4
Secondary Termination Enclosures.....	5
Decorative Street Lighting.....	6
Meter Bases.....	7
Temporary Boards.....	8
Guidelines.....	8
Diagram.....	9
Specifications.....	10
Underground Primary/Secondary.....	10
Decorative Street Lighting.....	11
Final Inspection Check List.....	12
Diagrams for Contractors.....	13
3 Phase Transformer Pad.....	13
Single Phase Transformer Ground Sleeve.....	14
Primary Vault Ground Sleeve.....	15
Pad mount Transformer Spacing.....	16
Labeling for Multi Metered Installations	17
Decorative Steet Light Footing Detail.....	18

All meter bases shall be Gallatin Dept. of Electric (GDE) approved meter bases, see GDE meter base policy. All meter base locations must be approved by GDE's Engineering Dept.

Construction

The complete use of underground (UG) electric facilities is required in all new commercial developments and, for all new commercial electric services unless specifically waived by the Gallatin Department of Electricity (GDE) Engineering Department. Overhead (OH) exceptions may be granted for major feeder lines on a case-by-case basis, but GDE's standard is underground. Exceptions will only be granted in letter form. All new commercial services shall be installed underground. The developer will submit a final plat approved by the City of Gallatin Planning Committee, provide an electronic cad layout and request an electrical layout from GDE, pay an aid to construction cost of \$45 per linear foot of underground/overhead feeder within development and aid to construction of 75% of the transformation cost required, provide all ditching and conduit, transport and place all vaults and required ground sleeves with a gravel base, pour all pads required as per GDE specs, call GDE for inspection of all ditching and conduit, backfill one foot, place marking tape, and complete backfill (See **GDE's Specifications**, pg.10 for requirements).

Provisions shall be made by the developer to loop feed each primary line where practical. GDE will provide and install underground primary wire, transformers, primary connections and switching cabinets. The developer/owner will install, own, and maintain all conduits (secondary & primary) that are necessary to serve their facilities/development, and all service wire. GDE will own all primary wire.

When the development requires the main line to be more than 200 amps on the primary lines but less than 400 amps, as determined by the Gallatin Department of Electricity (GDE), the developer will pay an aid to construction charge of \$65 per linear foot for any additionally required feeder lines.

When the development requires the main line to be more than 400 amps on the primary lines, as determined by GDE, the developer will pay an aid to construction charge of \$80 per linear foot for any additionally required feeder lines.

Overhead exceptions may be granted for major feeder lines as determined by GDE's Engineering Department on a case-by-case basis, but the standard will still be underground utilities. Exceptions will only be granted in letter form. Overhead lines require a 30' cleared easement provided by the developer/owner.

The developer shall be responsible for the cost of any line extension required to serve a development that is not within or adjacent to the current footprint of the Gallatin City limits and/or GDE's current service territory. Extension costs shall include: any expense of acquiring easements and needed right-of-way clearing as well as all construction labor and material necessary to reach the proposed development.

Any cost associated with a development that is above and beyond the GDE standard construction shall be at the expense of the developer. Costs could be back feed or redundant service requirements by the developer or below grade switchgear, or the like. GDE will maintain ownership of all primary infrastructure such as wire and transformers and be responsible for any replacement costs.

Underground service conductors installed on GDE poles will be all aluminum and limited to 2 runs and a maximum of 750kcmils. No compressed conductors may be used. GDE will assist in installing the conductor up the pole. GDE labor cost during this time onsite will be paid by the customer/developer.

Ownership/Repairs

Meter bases/CT cabinets/Tap boxes/etc., service conduit/wire from GDE's secondary equipment, and risers are the customer's property and the customer's responsibility to repair, maintain, and locate. This includes tree trimming for overhead services. GDE does not own, locate/mark (TN811 Call Before You Dig), maintain, or repair commercial underground service conduits or cables. GDE owns and maintains (does not include tree trimming) service wire and service connections on overhead services. Any meter bases with obstructed access or that have been enclosed by porches, decks, patios, fences, walls, screens, etc., will be required to be relocated by customer. Failure to do so during the allotted time provided by GDE will result in termination of service until work has been completed. Commercial customers changing out meter bases, risers, service entrance wires, or doing any major electrical work will be required to update service to GDE specs, pass any required City Codes electric inspections, as well as meeting all current National Electric Code (NEC) and National Electric Safety Code (NESC) requirements. Any overhead service installation must be approved by GDE's Engineering Department. A 30' cleared path will be required for all overhead services.

Multi-Unit/Multi-Service Buildings

Multi-unit buildings and buildings with multiple services shall have meter bases numbered to GDE specs (See **Labeling for Multi Metered Installations**, pg14). Multi-gang meter bases must be approved by GDE's Metering Dept. Meter troughs will not be allowed (see Secondary Termination Enclosures, pg4).

Secondary Termination Enclosures

GDE shall not connect to any new troughs. Secondary termination enclosures (provided by the Customer) will be used on all new services requiring multiple meters where ganged meter bases are not used. Existing troughs shall be replaced with secondary termination enclosures under the following circumstances: adding new load, upgrading service, adding a new service, or replacing GDE’s line side conductors.

Each individual service in the termination cabinet shall be labeled by unit number, suite number, or space number on the service cable for disconnect/reconnect purposes. The labeling must be approved by GDE’s Engineering Department. All conductors shall be routed behind the termination cabinet busbars.

Enclosures are the property of the Customer. There is a requirement for a GDE lock on these enclosures. A GDE employee will unlock the enclosure for the Customer when necessary and upon request.

The following are acceptable part numbers for termination enclosures. Any enclosure not listed must be approved by GDE’s Engineering Department.

CMC (Connector Manufacturing Company) Wall Mounted Three Phase							
Catalog Number	Max Wire Size	# of Cond. Per Phase	Dimensions - Inches			U.L. Listed Amp Rating	
			W	D	H	Copper	Aluminum
LWTE21-500	500 kcmil	21	32	16	51	3800	3100
LWTE14-750	750 kcmil	14	32	16	51	3325	2695
LWTE14-1000	1000 kcmil	14	32	16	51	3815	3115

Milbank Multi-Position Tap Box						
Catalog Number	Max Wire Size	# of Cond. Per Phase	Dimensions - Inches			U.L. Listed Amp Rating
			W	D	H	
UAP6094-O-NES	500 kcmil	16	25 5/8	16	43	3000
UAP6095-O-NES	500 kcmil	22	32 3/8	16	43	4000
UAP6096-O-NES	1000 kcmil	14	25 15/16	16	51	3300

A disconnect is allowed in front of the termination enclosure. A disconnect is not allowed between the termination enclosure and the meter base.

Decorative Street Lighting

The following guidelines are for use by the subdivision/development developer to assist with the installation of decorative street lighting on the Gallatin Department of Electric (GDE) system.

Standards

Decorative street lighting designed and serviced by GDE will only be allowed in areas with underground electric primary and City roads. If the road is private, GDE will not design or service street lighting. Any private road street lighting will be metered according to GDE specs.

GDE's Engineering Department will design and show the street lighting layout on GDE's conduit plan. The following general standards will be followed for the street lighting design.

1. A light will be placed at all public street intersections, roundabouts, and 90° turns.
2. A light will be placed in all cul-de-sacs
3. Standard spacing between lights will be approximately 300' with a max spacing of 400'.
4. Public alleys in residential neighborhoods will not have public street lighting provided.

Overview

The developer is responsible for the installation of all lights, foundations, conduit, and wire. The developer will choose lights from GDE approved lights and provide GDE with one (1) spare decorative streetlight for each fifty (50) installed. The cost of the lights will be charged as aid to construction cost. This cost must be paid before GDE will release any material. Decorative lights can be picked up from GDE's warehouse once received. Decorative streetlights must pass a City Codes electrical inspection, meet GDE's specs listed in **GDE Decorative Light Specs**, pg.11, and meet GDE's inspections listed in **GDE Decorative Light Inspections**, pg.11, before being energized. The developer will be responsible for repairs during the first year the light is energized.

Procedure to have lights energized

A decorative streetlight will not be energized until passing a City Codes final electrical inspection and GDE's final inspection. After inspections have been completed, the developer or HOA may have the lights turned on to utilize the outdoor lighting. The lights will be billed monthly according to GDE's Outdoor Lighting Rate to the developer or HOA until lights are converted to the City of Gallatin account. Lights in residential developments will be converted to the City of Gallatin account once a permanent resident has service turned on to a house feeding from the same transformer as the decorative light. In commercial developments, the lights will be converted to the City of Gallatin account once the commercial building has been energized in the final tenant's name. However, the developer or HOA may choose not to use the decorative streetlights and wait until the lights have been converted to the City of Gallatin account before being energized.

Gallatin Department of Electricity Approved Meter Bases



P.O.Box 1555
 Gallatin, TN. 37068
 (615) 452-5152
 (615) 452-6060 Fax

Self Contained

Size	Phases	Type	Milbank	Durham	Siemens	Eaton
200 Amp	Single	OH	U7021-DL-YG-BL	RS213N	UA13 / HQU4	UTRS2028CH
200 Amp	Single	UG	U1990-0-BL	UTRS223A	UAS8/UAS9 / HQW4	UTRS223ACH
225 Amp	Single	House Module			WCL2040811RJ	
320 Amp	Single	OH	U1079-R-BL		HQST 4	UTH4300TCH
320 Amp	Single	UG	U1797-0-K3L-K2L-BL		HQDSW/SWD 4	UTH43389UCH
320 Amp	Single	OH/UG	U2448-X	H4330T		UTH4330TCH
200 Amp	Three	OH/UG	U7423-RXL	H7213T	HQND 5	
200 Amp	Three	OH/UG	U9701-RRRL-BL		HQST 7 / HQW 7	
225 Amp	Three	Module			WCL2040821RJ	
225 Amp	Three	Module			WCL2442B311RJ	
320 Amp	Three	OH/UG	U2120-X	UT-H7330-U	HQST 7	
320 Amp	Three	OH/UG	U2594-X		HQDSW/SWD 7	
600 Amp	Three	OH/UG	U4887-xt-9508		(K-71) 9817-9508	CH9508K7

Instrument Rated

Size	Terminals		Milbank	Durham	Siemens	Meter Devices
20 Amp *	8	Single Phase	UC7235-RL	R8821-8K	9804-8542	
20 Amp **	13	Three Phase	UC7461-RL	STS13-2K	9837-8512	W110U54522-5

Pedestal Service Entrance

Size	Terminals		Midwest			
200 Amp	4		R28TC1P6H			

- * 8 Terminal Base Requires Automatic Bypass Switch
- ** 13 Terminal Base Requires test switch Durham # 1058 or Milbank # TS10-0111 (10 Pole)
- ** 13 Terminal Base Must be prewired with test switch

Specifications and Notes

1. **NON-APPROVED METER BASES WILL NOT BE ENERGIZED BY GDE**
2. Steel Construction and UL Approved with Label
3. Location shall be approved by GDE's Engineering Dept.
4. Shall be surface mounted and on a permanent structure controlled by the Customer.
5. Shall not be in areas that are closed off by porches, decks, patios, fences, walls, screens, etc.
6. GDE shall have unobstructed access to meter base.
7. Shall have a 6' clearance from any obstruction in front of meter base.
8. Shall be mounted 5'8" from ground to center of meter base.
9. GDE/Customer service wire will enter left side of meter base, customer load wires will exit right side facing meter base
10. Shall be installed to National Electric Code (NEC) requirements.
11. Instrument Rated bases shall have shorting ability to remove meter
12. 600 Amp and above services REQUIRE advance notice to be given to GDE Meter Department. Call 615-527-7006 or 615-527-7005.

Instrument Transformers

1. All CT and PT's shall be provided by GDE.
2. Single Phase CT cabinet size shall be 36 x 36 x 12 with a 3/4 inch plywood backing for mounting of Instrument Transformers. Steel or aluminum construction.
3. Three Phase CT cabinet size shall be 48 x 48 x 12 with a 3/4 inch plywood backing for mounting of Instrument Transformers. Steel or aluminum construction.
4. CT cabinet must have provisions for a padlock.
5. Single Phase - Electrician shall provide 5 wires, (BLACK, RED, BROWN, ORANGE, WHITE)
6. Three Phase - Electrician shall provide 7 wires (BLACK, RED, BLUE, BROWN, ORANGE, YELLOW, WHITE)
7. No marking tape shall be used on wires.
8. All CT and PT wires, 100' or less, shall be #12 copper conductor. Distances over 100' require approval from GDE.

Multi Ganged, Stacked meterbases, and Module Bases are APPROVED on a case by case bases.

Submit information to:

bthornton@gdetn.com
ghoore@gdetn.com

Temporary Electric Service Policy

The Gallatin Department of Electricity (GDE) will provide electricity to customer owned temporary boards according to the following guidelines.

1. Temporary boards must be labeled with the address and lot number and pass an electrical inspection by the State Electrical Inspector each time the board is installed or relocated.
2. Temporary boards must be an underground fed temporary board unless approved by GDE's Engineering Department.
3. Temporary board location must be approved by GDE's Engineering Department.
4. Temporary boards that are approved for overhead installation shall be rigidly installed in the ground (2' min for post and braces) with braces or guys to adequately support the overhead service conductors and the weight of a 250lb man on a ladder, leaned against the temporary board. There shall be an eyebolt attachment for GDE's service conductors. The attachment point and ground clearance to service wire shall meet the National Electric Code (NEC) and National Electric Safety Code (NESC). The overhead temporary board shall not be installed more than 100' from GDE's approved pole.
5. GDE will charge a \$100.00 temporary board fee. This amount covers the installation and removal of the service wire. If additional trips are made, there will be extra charges. This charge does not include the meter service charge and deposit.
6. In addition to the cost from line 5, temporary boards requiring more than 100' of overhead service wire or when temporary construction is required, the total installation and removal cost will be paid by the customer before work will begin. The cost to install a transformer to feed a temporary board will be \$400.00.
7. Customers or contractors will not remove a temporary board until the meter and service wires have been disconnected and/or removed

GENERAL CONSTRUCTION NOTES:

- 1) The GDE engineer will spot the temporary board location upon request.
- 2) The temporary board shall be installed at least 3' from and no more than 18" from GDE's approved service point.
- 3) Temporary electric service boards are not to be installed on GDE poles or trees.
- 4) Each temporary board must be labeled with address and lot number, and pass an electric inspection by the State Electrical Inspector each time the board is installed or relocated.
- 5) The temporary board clearance from other objects must meet all NEC and NESC requirements.

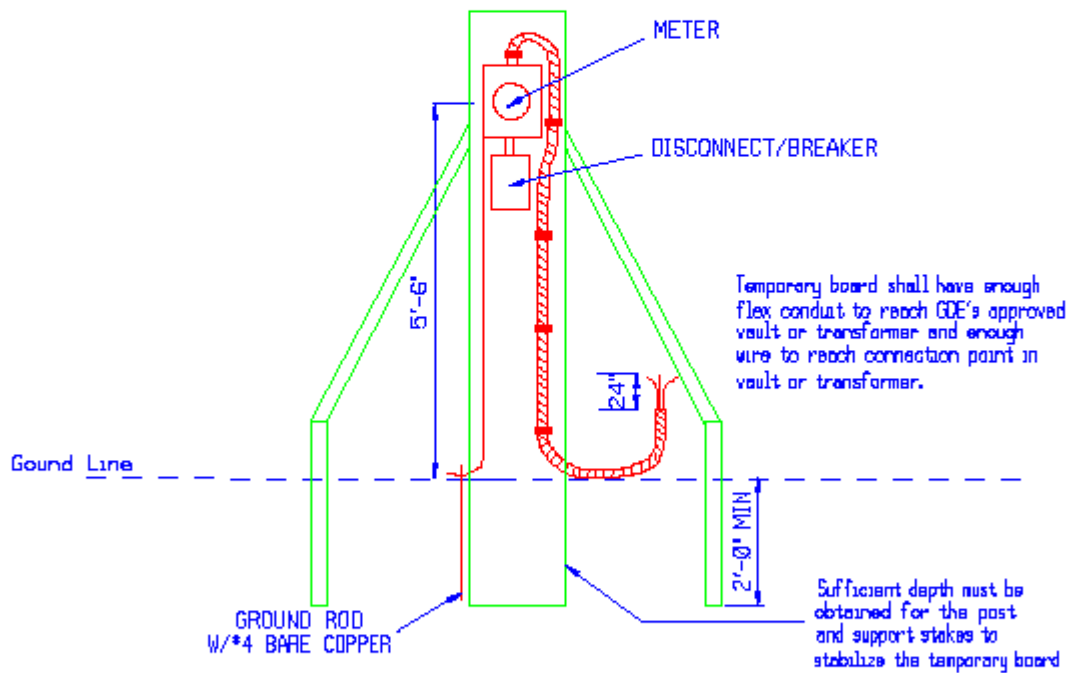

IMPORTANT NOTE:

CUSTOMERS OR CONTRACTORS WILL NOT REMOVE A BOARD UNTIL THE METER AND THE SERVICE WIRES HAVE BEEN REMOVED.

GDE	UNDERGROUND TEMPORARY BOARD SERVICE	DATE 2/14/14
		STANDARD NUMBER UG TB

Material	GDE Specs
Conduit	*1" schedule 40 PVC (unless otherwise specified) with 24" radius elbows
Decorative Fixtures	*See Approved Light Fixtures
Decorative Pole	*See Approved Light Poles
Lamps	*See specs listed in Approved Light Fixtures
Photocell	*See specs listed in Approved Light Fixtures
Conductor	*NEMA Listed THHN/THWN Copper, 600v, 90° C #12, #4, or #6 AWG (must maintain less than 5% voltage drop from source).
Pole Base Fuses and Fuse Blocks	*Fuse link with fuse installed required in pole base.

GDE Decorative Light Specifications.

GDE Decorative Light Specifications

GDE Decorative Light Inspections

Note: The conduit, footing, and final inspections below are done by GDE and not by City Codes.

Inspection	Requirements
Conduit	<ul style="list-style-type: none"> *Conduit will be inspected by GDE prior to backfilling ditch. *All work shall be performed to GDE's conduit drawings and details. *2'-0" depth with minimum of 12" separation (vertical and horizontal) from other utilities. *Backfill shall be soil free of material that may damage conduit or gravel. *Conduit damaged before lights are energized must be replaced by developer. *All conduit installed in existing GDE equipment must be coordinated with GDE.
Footing	<ul style="list-style-type: none"> *Shall be built to GDE Decorative Street Light Footing Detail (pg.23). *First GDE footing inspection shall be scheduled before concrete has been poured. Rebar, anchor bolts, ground wire, and ground rods shall be installed. *Second GDE footing inspection shall be scheduled after concrete has been poured. *Poles shall not be installed until second inspection has been completed.
Final	<ul style="list-style-type: none"> *Light must pass a City Codes electrical inspection before scheduling the final GDE inspection. *All wiring, connectors, and fuses installed. *Poles plumb, level, and securely mounted. *Fixture oriented correctly with street. ("street side" embossed on fixture must be turned toward the street)



GALLATIN DEPARTMENT OF ELECTRICITY
P.O. BOX 1555 • 135 JONES STREET
GALLATIN, TENNESSEE 37066
(615) 452-5152 • FAX (615) 452-6060
www.gallatinelectric.com

GDE Final Conduit Inspection Check List

This checklist is to assist developers with the requirements for a GDE final conduit inspection. Please ensure the requirements have been met before signing, dating, and returning form to GDE for a final conduit inspection. This list is meant to be a guide and is subject to change without notice. Specifications available www.gallatinelectric.com/engineering.

- 1. Property Pins installed and labeled.
- 2. Curbs installed.
- 3. Grade within 6" of final grade from back of utility easement to curb.
- 4. All GDE conduits and ground sleeves installed in utility easement.
- 5. All secondary vaults installed per GDE Secondary Vault Detail.
- 6. Ground sleeves installed per GDE Ground Sleeve Details.
 - 6A. Ground sleeves backfield to within 6" of top of pad.
 - 6B. Ground sleeves level.
 - 6C. Conduits cut 12" below top of ground sleeve
 - 6D. Conduits arranged in ground sleeve per the GDE Ground Sleeve Details.
 - 6E. No trash inside of ground sleeve.
- 7. Conduits arranged per GDE Underground Distribution spec for underground primary construction, or GDE Underground Secondary Conduit System spec for overhead primary construction.
 - 7A. 36" minimum spacing between GDE 3" secondary conduit and communication conduits.
 - 7B. 18" minimum spacing between GDE ground sleeve and communication conduits on underground primary construction.
 - 7C. 24" minimum spacing between pole and GDE 3" secondary conduit on overhead primary construction.
- 8. 1800lb minimum pull tape/mule tape in all conduits with 6' tail on each end.
- 9. All conduits installed per GDE Conduit Layout.
- 10. Any work done to unstop, repair, etc. after final inspection will be billed to developer at full cost.

Signature: _____ Date: _____

LIGHTING THE WAY FOR THE CITY OF GALLATIN

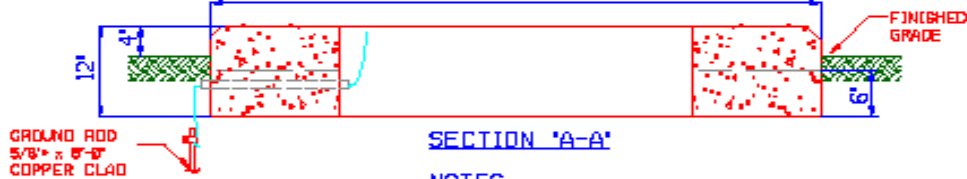
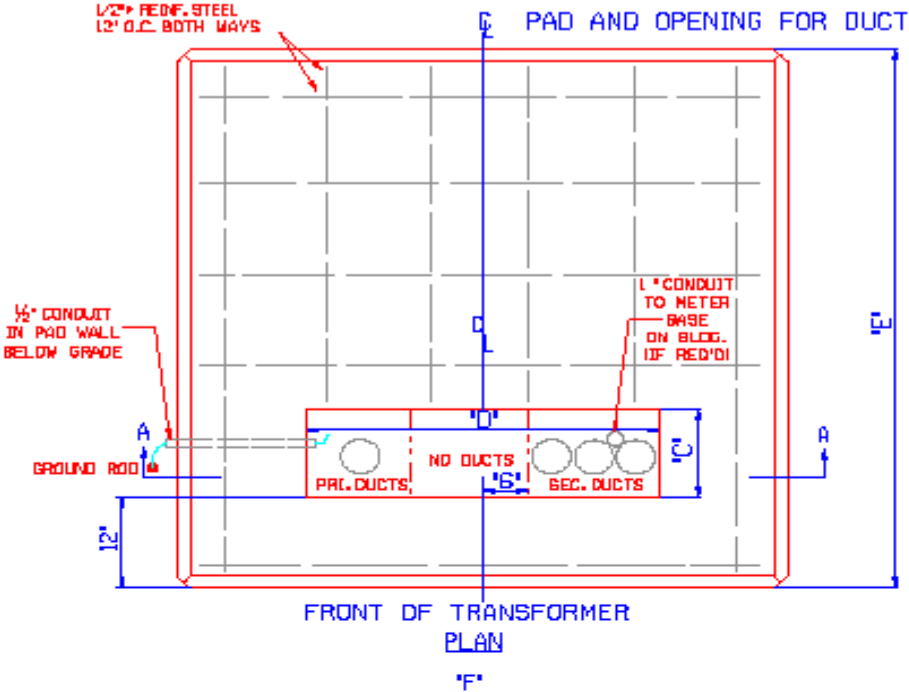

SECTION 'A-A'

NOTES:

- 1- Concrete testing, 2,000 lbs. psi minimum.
- 2- Reinforcing steel, ASTM-A615 Grade 60, placing approximately 12' D.C. each way and securely tied together.
- 3- Conduits to stop a maximum of 1' above pad.
- 4- Conduits to be placed as shown. Allow at least 12' between pri. and sec. conduits.
- 5- Primary conduits shall be 48\" deep and have rigid galvanized elbows.
- 6- GDE to be notified after forming, but before pad is poured for an inspection of the pad.
- 7- Float finish, leaving no depressions.
- 8- Conduit damaged before wire is installed must be replaced/repared by developer.

DIMENSION	C	D	E	F
75 KVA	12'	48"	84"	84"
150 KVA	12'	48"	84"	84"
225 KVA	18'	48"	84"	84"
300 KVA	18'	48"	84"	84"
500 KVA	18'	52"	84"	84"
750 KVA	18'	52"	84"	84"
1000 KVA	24'	52"	84"	84"
1500 KVA	24'	52"	84"	84"
2000 KVA	24'	60"	120"	120"
2500 KVA	24'	60"	120"	120"

GDE

CONCRETE PAD DETAIL
THREE PHASE PAD MOUNTED
TRANSFORMER

DATE 2/18/13

STANDARD
NUMBER
UM-3P

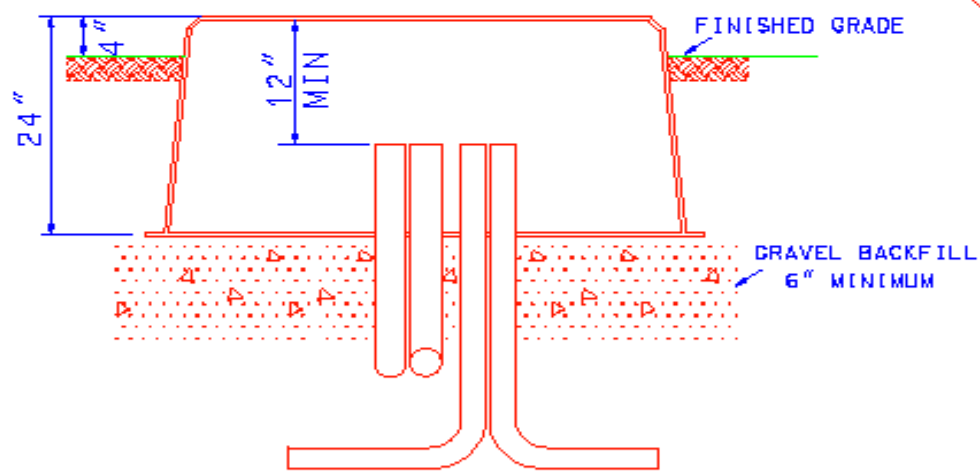
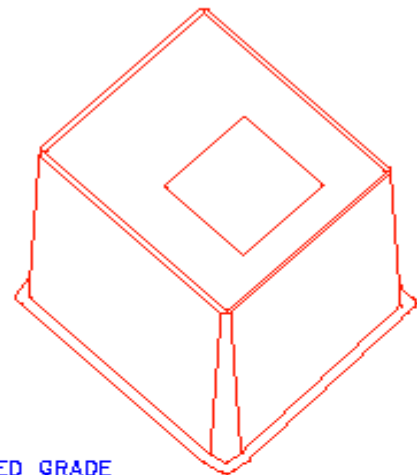
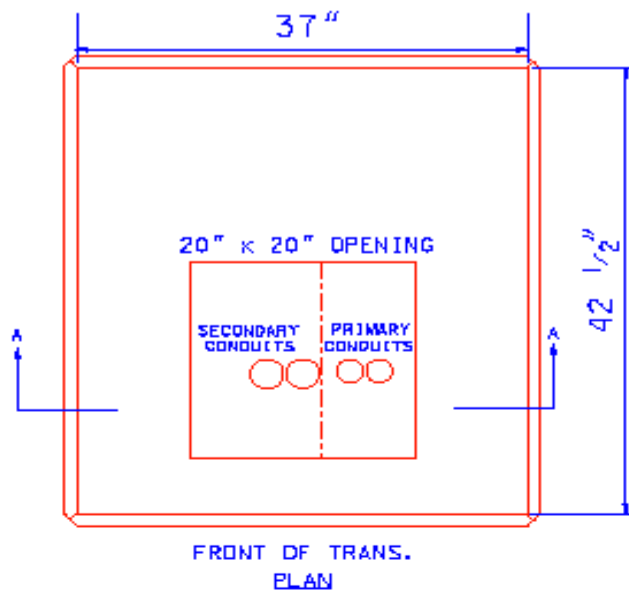

NOTE:

- 1 - PRIMARY & SECONDARY CONDUITS TO BE LOCATED AS SHOWN ABOVE.
- 2 - CONDUITS TO STOP AT LEAST 12" BELOW TOP OF PAD.
- 3 - PRIMARY CONDUITS TO BE 48" DEEP.
- 4 - SECONDARY CONDUITS TO BE 30" DEEP.
- 5 - SLEEVE TO SET ON GRAVEL BACKFILL FROM BOTTOM OF DITCH TO PAD BOTTOM.
- 6 - CONDUIT & SLEEVES DAMAGED BEFORE WIRE IS INSTALLED MUST BE REPLACED/REPAIRED BY DEVELOPER.

GDE	TRANSFORMER GROUND SLEEVE DETAIL	DATE 2/15/13
	SINGLE PHASE	STANDARD NUMBER UMF-1P

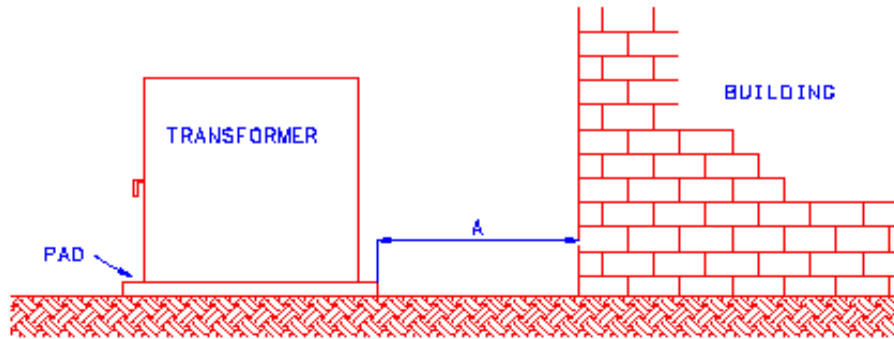

<u>DIMENSION A</u>	<u>TRANSFORMER KVA</u>	<u>BUILDING WALL & EAVES</u>
10'	0-75	NOT FIRE RESISTANT
20'	76-333	NOT FIRE RESISTANT
30'	334 AND LARGER	NOT FIRE RESISTANT
3'	ALL SIZES	FIRE RESISTANT (8" BRICK, ETC.)

ELEVATION VIEW

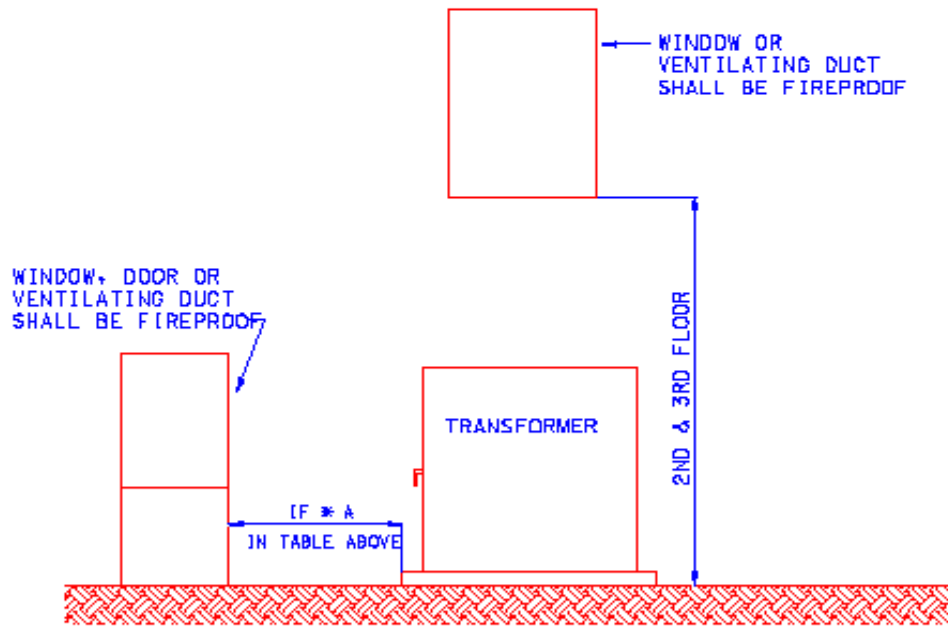

ELEVATION VIEW

GDE	TYPICAL SITING REQUIREMENTS FOR PAD-MOUNT TRANSFORMER	DATE: 11/30/00
		STANDARD NUMBER UMT-1

Wiring troughs are no longer allowed, must now use secondary tap boxes.

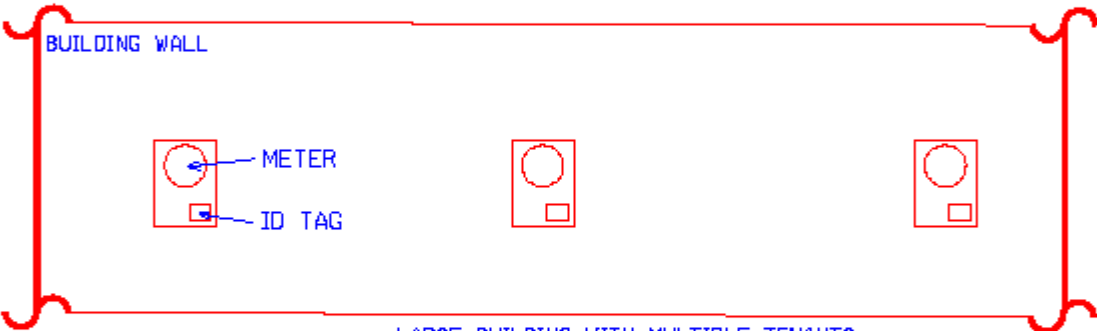
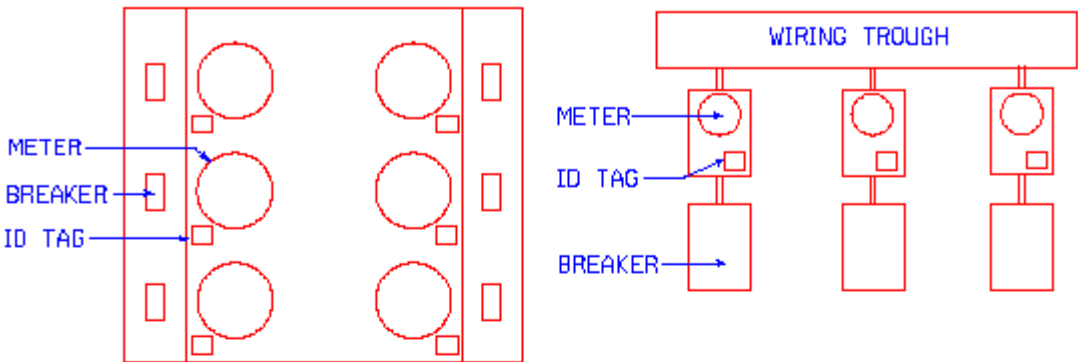

LARGE BUILDING WITH MULTIPLE TENANTS

NOTES:

- 1- Buildings such as apartment buildings, retail strip centers, duplexes, triplexes, town homes, and etc. which have more than one meter shall have all meters labeled to identify the premises they serve.
- 2- The label shall have the apartment/building number or street address.
- 3- The label shall be outdoor rated brass or stainless steel.
- 4- The labels shall be attached to the meter base with rivets or screws.
- 5- The identification numbers/letters shall be stamped or engraved.
- 6- The identification numbers/letters shall have a character size of at least 1/8" in height.

<h1>GDE</h1>	LABELING FOR MULTI-METERED INSTALLATIONS	DATE 7/28/15
		STANDARD NUMBER LAB-1

